

-ARCO

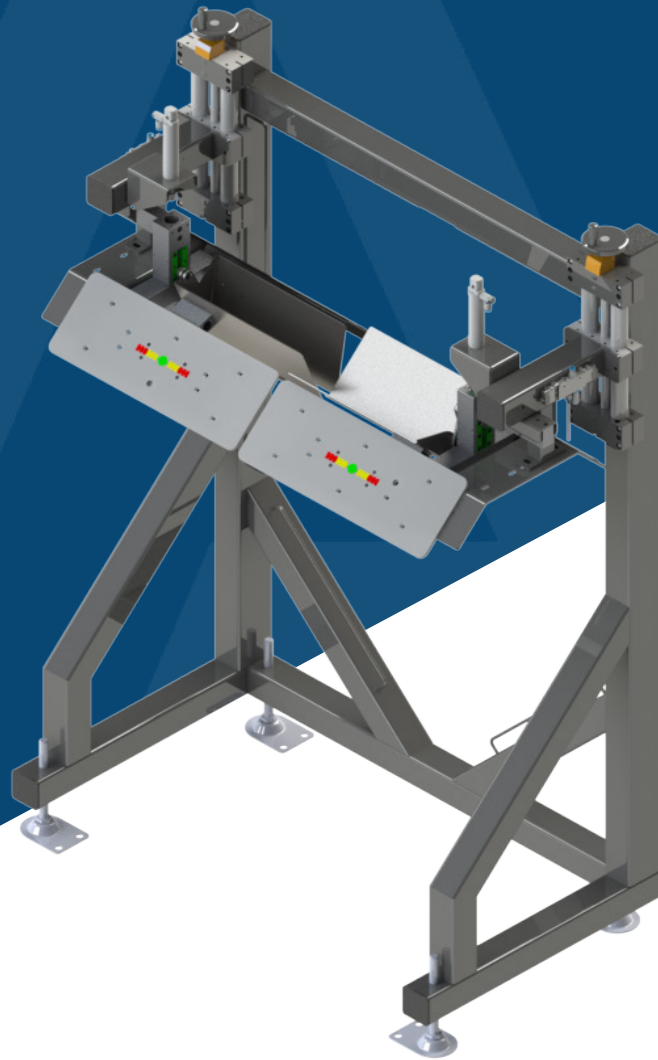

Bucket weigher

Accurate weighing system

The bucket weigher is suitable for processing any recipe between 0,5 and 500 grams. The desired weight per recipe is freely adjustable.

Starting from recipes, the capacity per bucket weigher depends on the difficulty of the product and the handiness of the operator. Only 1 operator can work with 2 buckets. The bucket system works within a very small accuracy range, up to 0,5 grams, and is specially designed for weighing herbs and salads.

LED Indicator

On each weighing bucket, the LED indicator shows the actual weight in the bucket.

The operator sees at an instant if more or less product need to be placed or removed from a bucket to reach the desired weight. By weighing products in this way, the weight per bucket is more stable and the loss due to overweight is lower.

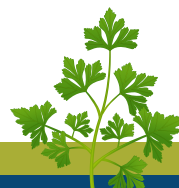

Ask our experts about the possibilities for your application and see what our machine can do for you.

✉ agri-food@arco-solutions.nl



CALL US NOW!

+31 (0) 88 006 5300

Specifications

Application

- Herbs & salad product weigher
- Extremely user-friendly system
- Capacity up to 10-15 drops /min
- LED indicator
- Multiple recipe structures
- Any recipe between 0,5 and 500 grams
- Faster throughput, so fresher packaged
- 24/7 remote service access
- OEE- Date per recipe

Benefits

- Operated by only 1 operator
- Less loss due to overweight
- Less human errors
- Less floor space required
- Low investment
- Proven weighing technology
- Connectable with all kind packaging machines

Optional extras

- End checkweigher
- Metal detector + rejector
- Crate (DE) stackers
- Print & apply
- Rotating buffer table

Machine type		Bucket weigher
Manufacturer		ARCO Solutions
Noise level		40 dB (A)
Electrical supply	Voltage	400 Vac
	Phase	3F+N+aarde
	Frequency	50 Hz / 60 Hz
	Power	1 kW / 3A
Compressed air	Quality	ISO norm 8573-1:2010
	Class	1.4.2 Norm
	Filter	0,1 µ - Dry
	Air connection	3/4"
	Incoming pressure	6 - 8 bar
	Average consumption	85 l/min

